

STACKABLE PARTITION DOOR SYSTEM FDPN40V1D Installation Manual (Perpendicular Stacking)

Thank you for selecting our product. Before starting installation, please read this manual thoroughly to ensure correct installation. Please keep this manual at hand for future reference.

ABOUT THE PRODUCT

- This product is parts set for installation of sliding partition for indoor use.
- It is possible to stack panels at a side with 90 degree rotation.
- Since panels are suspended, no bottom track is needed. Thanks to exclusively designed rollers, smooth movement of panels are realized.

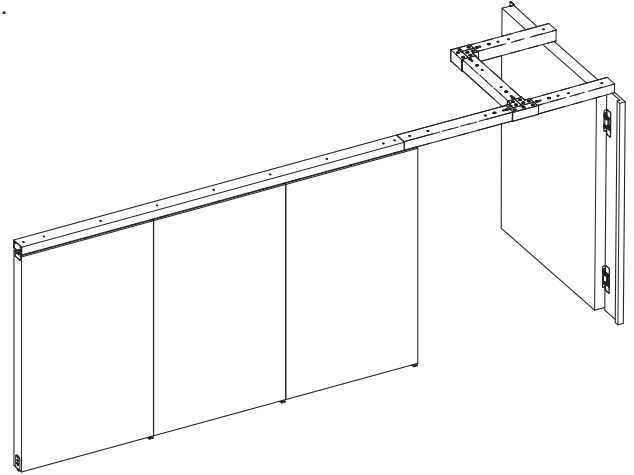

APPLICABLE PANELS

Partition face	Number of panels	Panel width	Panel height	Panel thickness	Panel weight (each panel)	Panel vertical adjust range
One	3 to 6 (※ ¹)	500 - 900 mm (※ ¹)	Max. 2500 mm	34 - 40 mm	Max. 40 kg	Upward: 0 mm Downward: 7 mm

※¹ These sizes are available by the choice of stacking track.

FOR YOUR SAFE WORK AND CORRECT INSTALLATION

Meaning of symbols

 Warning Caution	 Prohibited	 Required
---	---	---





! WARNING If not followed, death or serious injury may result.

- ❗ This partition door system should be installed by a qualified person. If the system is not installed correctly, the panel will not operate smoothly, and may cause injury.
- ❗ It is necessary to manufacture the frame with sufficient strength so that it endures the weight of the panel and any impact upon opening / closing the panel. Only use designated screws and ensure that they are fastened firmly. A frame with poor strength or loose screws might result in the panel falling and causing injury.
- ⊘ Do not try to use this product for anything other than its original purpose. Do not use any part for applications outside of its specification.
- ⊘ Do not disassemble nor modify any parts other than those described in this document.

! Caution If not followed injury or damage may result.

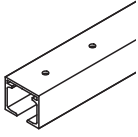

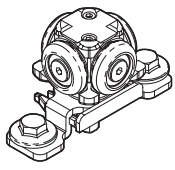
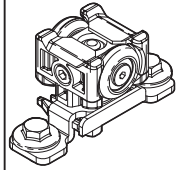
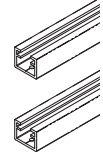

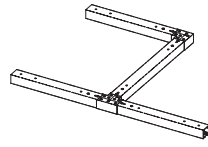
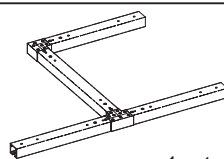
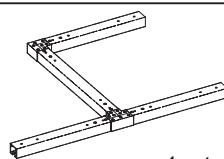
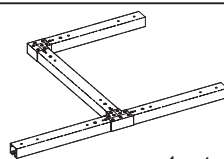

- ❗ This product is a part for architectural fittings. After installation, make sure to test the finished product thoroughly to ensure that it is well-functioning and safe.
- ❗ Make sure to follow the designated dimensions, specifications, and horizontal/vertical angles. Make sure that the frame is not warped, since it may affect the movement of the panel.
- ❗ If cutting any parts, make sure to remove any burrs before installation. Also check the upper rail for any left-over burrs or scraps and remove these.
- ❗ When using electric tool, pay attention to avoid over-tightening.
- ❗ Make sure to check the screws for slack at regular intervals (one month from first usage, half a year, and then one time every year is recommended).

COMPONENT PARTS

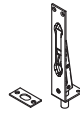
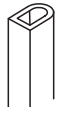
		①	②	③	④	⑤	⑥	⑦
Left or right stacking	No. of panels	Upper track  There is also a recessed mount separately.	Stacking track * Refer to the table on page 3 for the choice of stacking track.	Connecting plate (one piece attached to ②) 	Recessed rollers for stackable door 	Recessed rollers for stackable panel 	Hanging bracket (2 pcs/set) 	End cap 
Left stacking	3	1		1	3 sets		3 sets	6
	4				4 sets		4 sets	8
	5	2		2	5 sets		5 sets	10
	6				6 sets		6 sets	12
Right stacking	3	1		1	3 sets		3 sets	6
	4				4 sets		4 sets	8
	5	2		2	5 sets		5 sets	10
	6				6 sets		6 sets	12

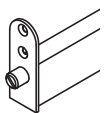
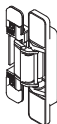
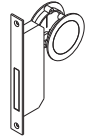
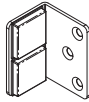
Stackable door is included in "No. of panels".

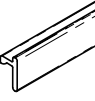
Attachment: Adjust spanner (1 pc)

Optional Parts	⑧	⑨	⑩	⑪	⑫	⑬	⑭	⑮	⑯	⑰	⑱	⑲
No. of panels	Flush bolt 	Gasket 	Counter part for gasket 	Door bottom tightener 	Hinge 	Magnetic Latch Handle 	Door Stopper 	End plate FDP40-TREP 	Stopper FDP40-ESTP 	Gap cover 	Catch A 	Catch B 
3	3	2	2	3	2 - 3	1	1	-	-	1300mm	Set of 4pcs	2 per storage panel over 700 wide, 4 to 6 per opening door. (P.16)
4	4	3	3	4								
5	5	4	4	5								
6	6	5	5	6								
	Must be used on stackable panel to lock.	Must be used to hide the gap between panels. To be used by pairs.	To hide the gap between panel and floor.	To hide the gap between panel and floor.	Use for a swing door when the panels are closed. These three parts are used in set.			To cover the end of track (This is not a stopper.)	For upper track For stacking track	For concealing gaps between upper rail and panel.		

POSITION OF PANELS

Right stacking

Left stacking

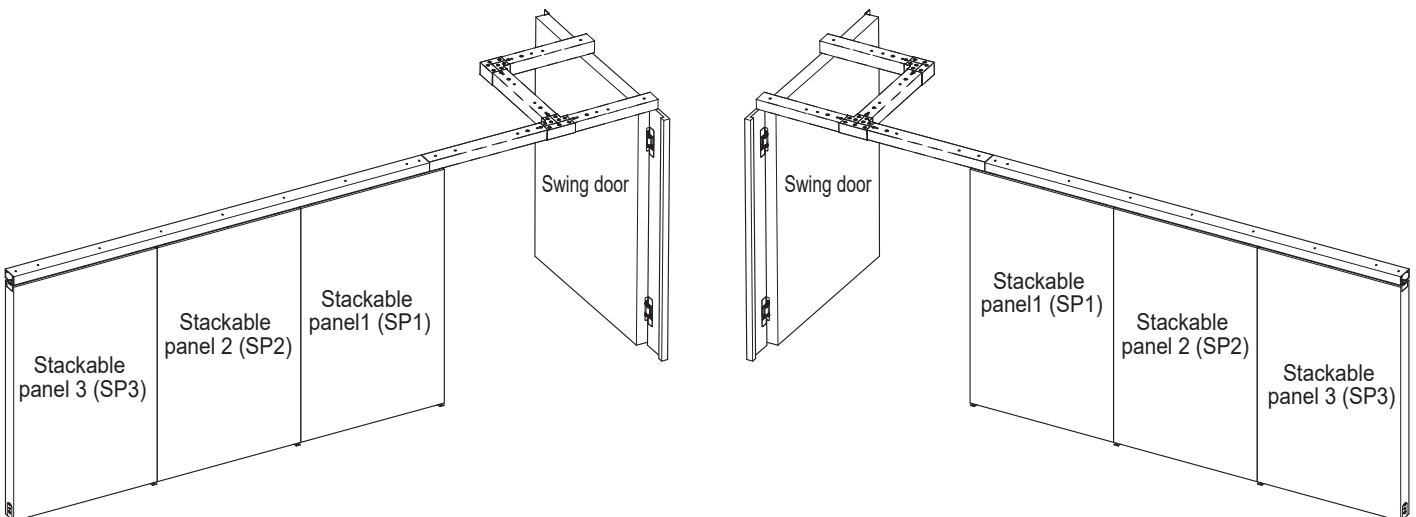

Parts for each panel (Optional Parts)

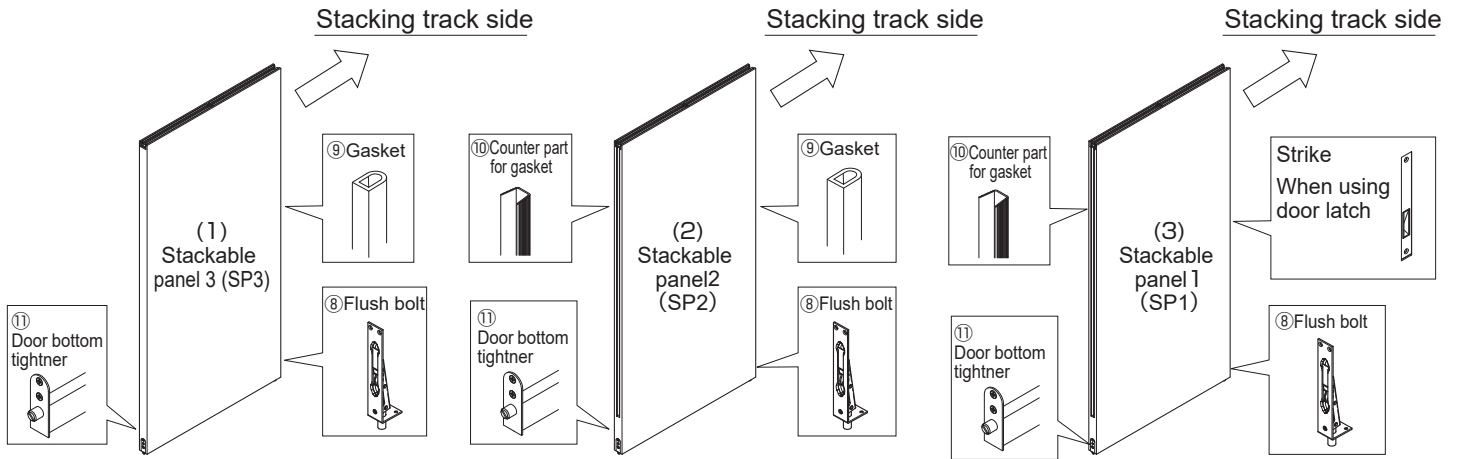

INSTALLATION DRAWING (EXAMPLE)

This document uses the surface mount rails to provide installation instructions.

Stacking track	Left or right stacking	No. of panels	Dimension of stacking track				Panel width	Hanging bracket				
			P	D	Ps _r	Ls _r		Stackable panel	Part No.	Lh		
FDPN40V-TRMSL-P34D40	Left	3 - 4	340	400	386	660	500 - 700	FDP40-DTR240	240			
FDPN40V-TRMSR-P34D40	Right											
FDPN40V-TRMSL-P54D40	Left		540	540	586	800				700 - 900	FDP40-DTR340	340
FDPN40V-TRMSR-P54D40	Right											
FDPN40V-TRMSL-P54D54	Left	5 - 6	540	540	800	700 - 900	FDP40-DTR340	340				
FDPN40V-TRMSR-P54D54	Right											

The drawing shows the installation of right stacking. In case of left stacking, positions and direction of the parts are mirror image.

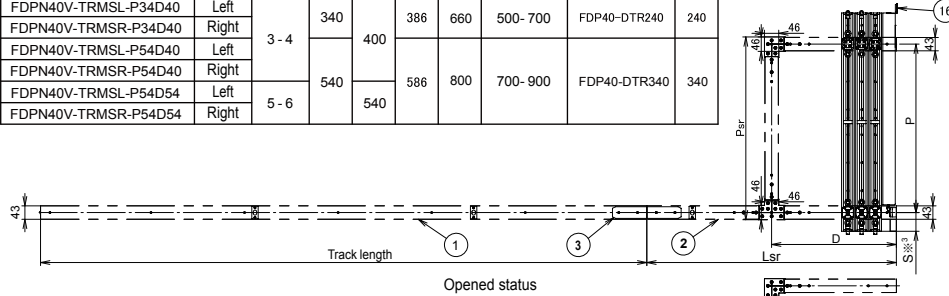

※² When using HES 3D - V135 hinge

※³ When using stacking track (P = 340)

In case $500 \leq PW \leq 580$

S = 60

In case $580 < PW \leq 700$

S ≧ PW - 520

S = 60° is also possible if hanging brackets are so that upper roller can be shifted to desired positions.

When using stacking track (P = 540)

In case $700 \leq PW \leq 780$

S = 60

In case $780 < PW \leq 900$

S ≧ PW - 720

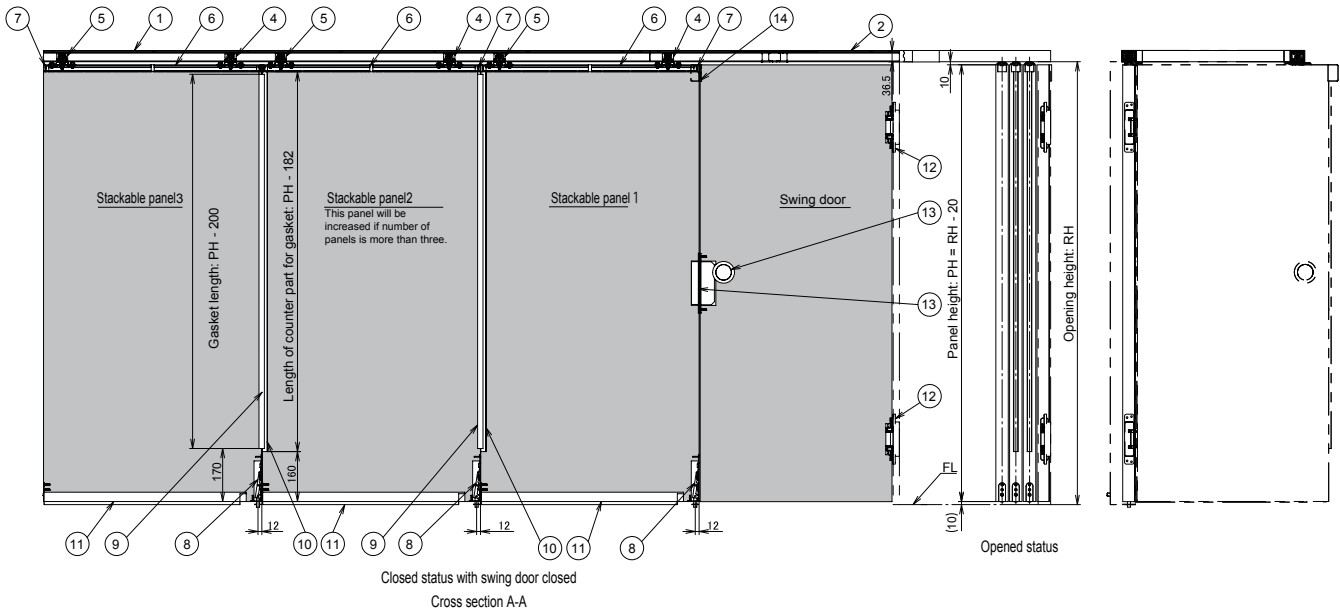
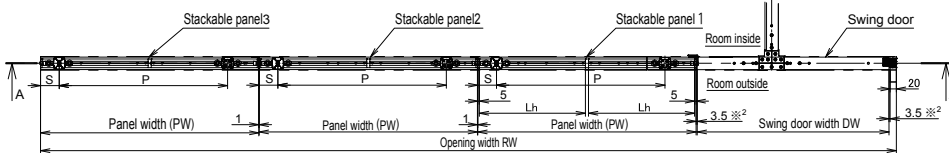

PANEL PROCESS DIMENSIONS

As for the dimensions in , please refer to the manuals of respective products (Latch Handle, Strike, Hinge)

● Stackable panel1 (SP1)

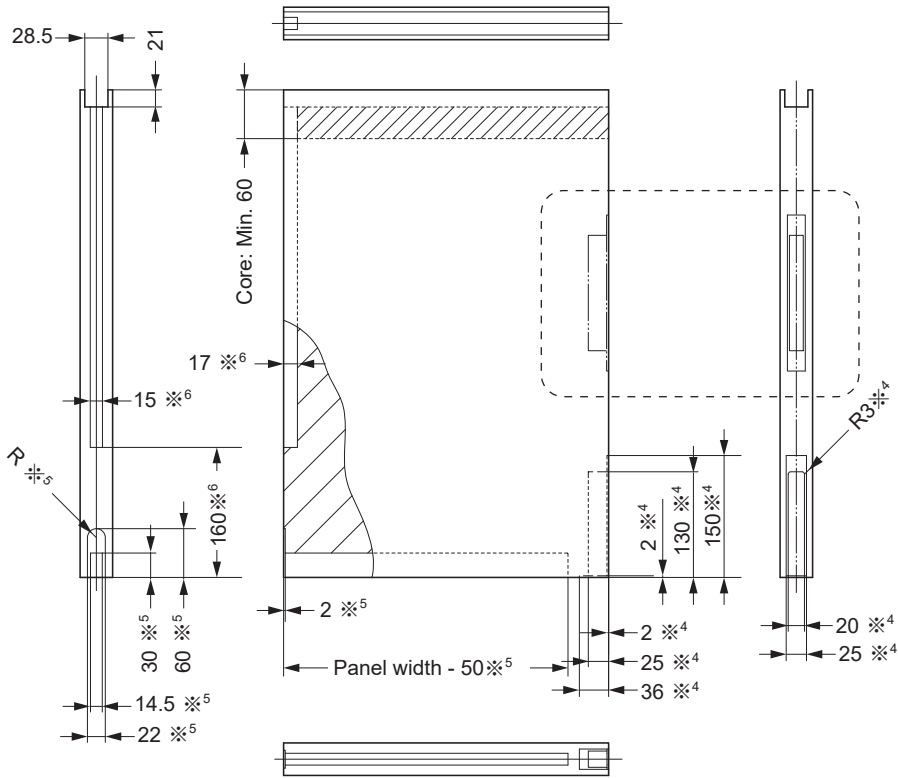

● Stackable panel 2 (SP2) - This panel will be in creased if number of panels is more than three.

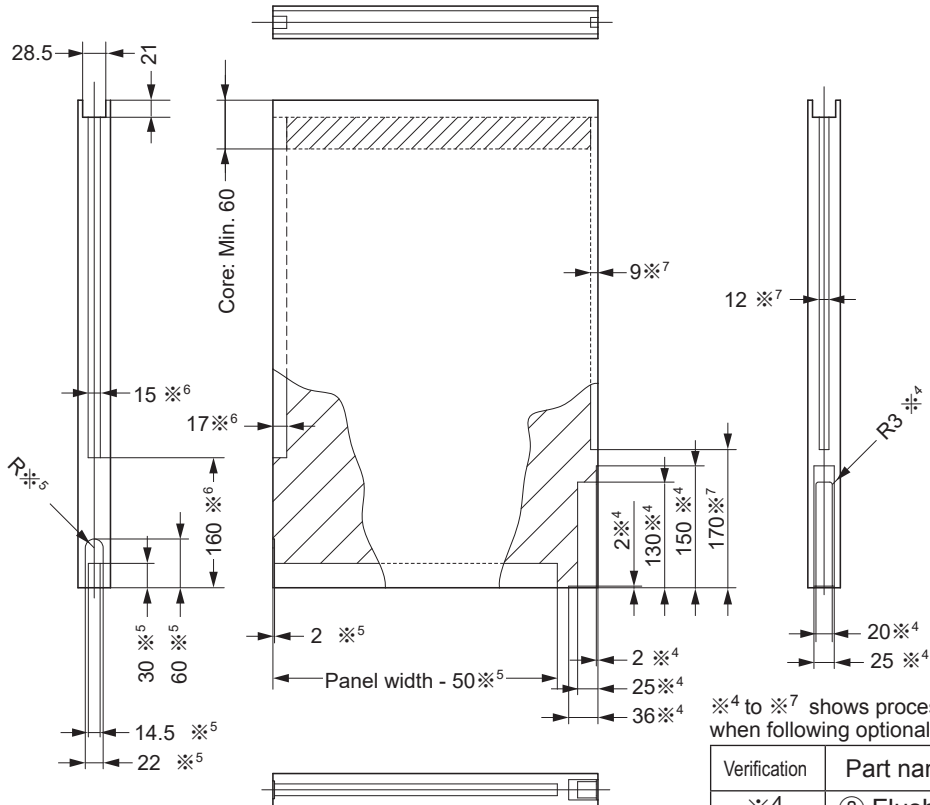

※4 to ※7 shows process dimensions only when following optional parts are used.

Verification	Part name
※4	⑧ Flush bolt
※5	⑪ Door bottom tightner
※6	⑩ Counter part for gasket
※7	⑨ Gasket

● Stackable panel 3 (SP3)

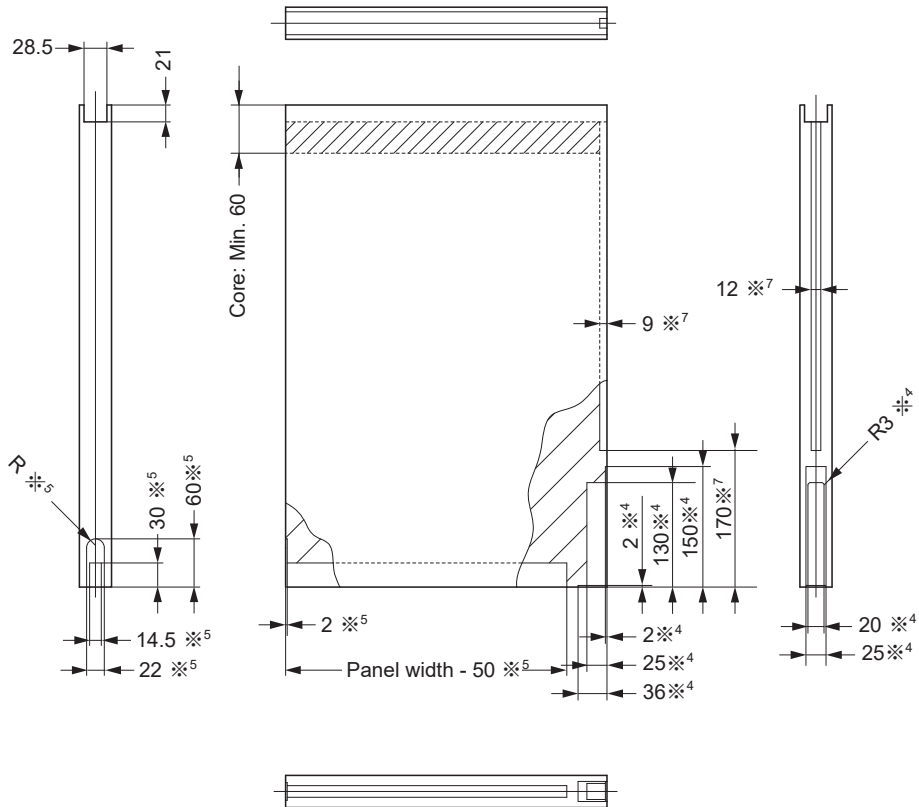

● Swing door Note that dimensions with ※⁸ are different in left stacking and right stacking.

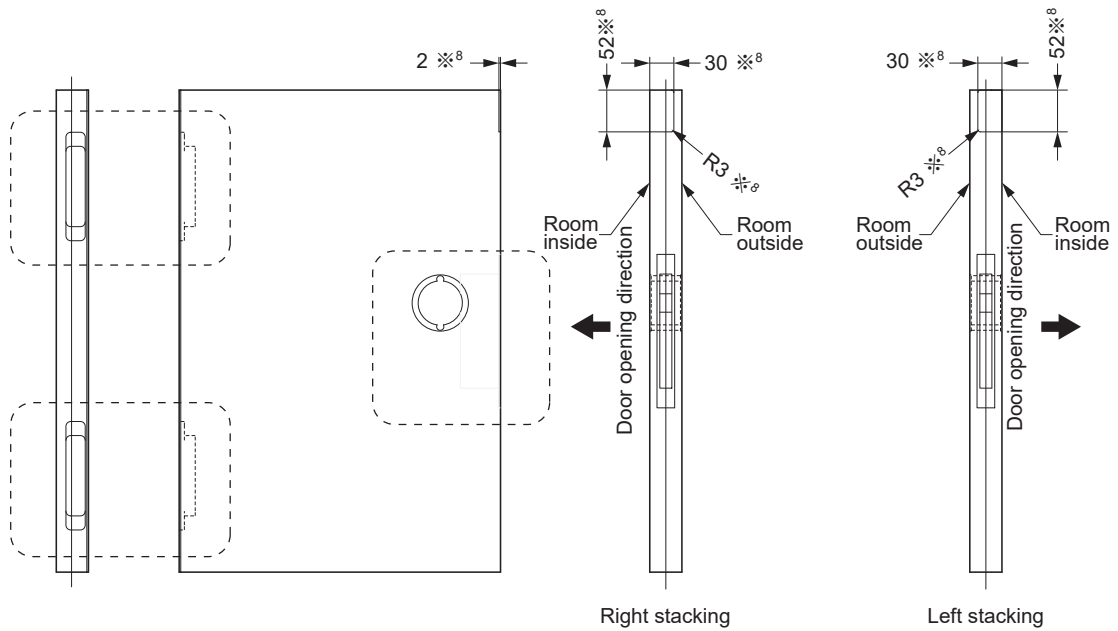

※⁴ to ※⁸ shows process dimensions only when following optional parts are used.

Verification	Part name
※ ⁴	⑧ Flush bolt
※ ⁵	⑪ Door bottom tightner
※ ⁶	⑩ Counter part for gasket
※ ⁷	⑨ Gasket
※ ⁸	⑭ Door stopper

CHECK POINTS FOR INSTALLATION

[1] Structure of beam

Arrange a beam for track with reinforcing material to prevent track from warping.

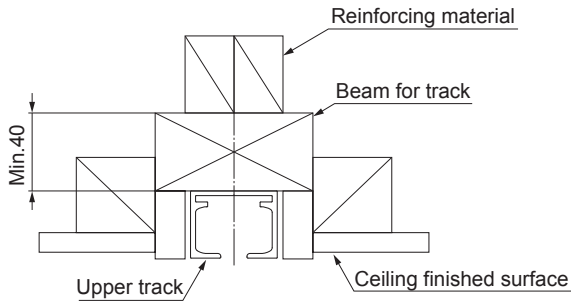

Make sure that the ceiling is strong enough to support a load of 240 kg

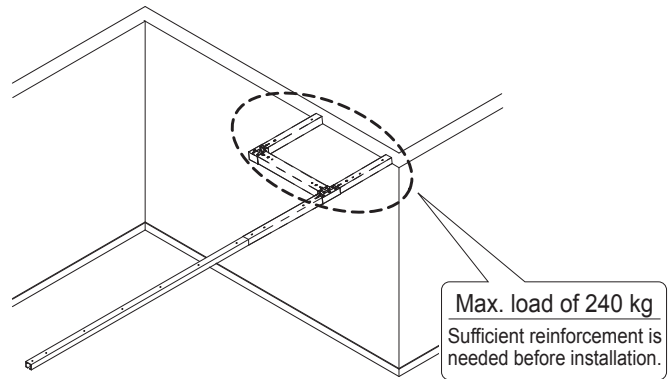

[3] Process when recessing the track

The groove should be processed so that the track would not be deformed.

- Width of groove
- Right angle
- Parallel

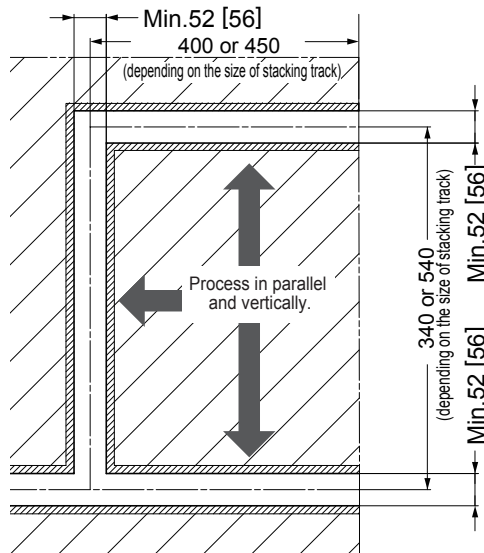

Dimension in [] denotes when cloth is added.

[2] Check the ceiling for sag and floor for warp

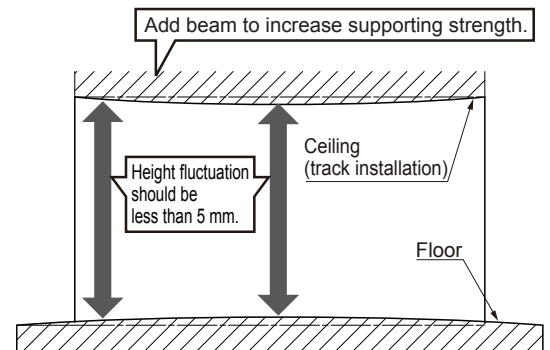

Cross section

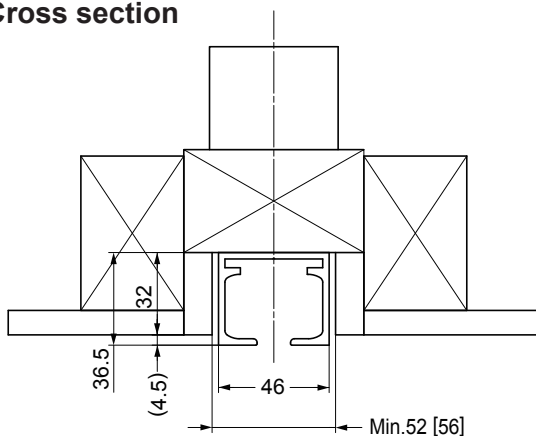

When processing without gap between ceiling face and track

① Mount track.

② Process ceiling surface.

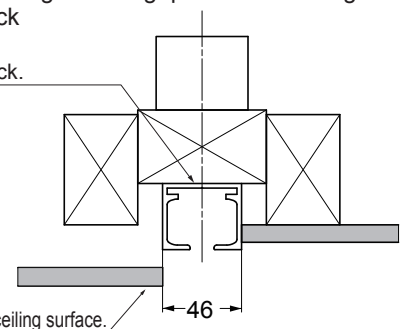

TOOLS NEEDED FOR INSTALLATION

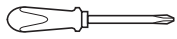

Phillips Screwdriver #2



Screwdriver ※11

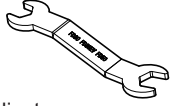

Adjust spanner
Order code: 250-017-168
Part No.: FD30-FSP



Spanner 10 mm

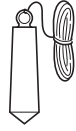

Plumb ※9



Pan head tapping screw ※11

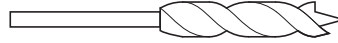

Drill bit: φ12 ※9

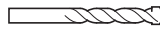

Drill bit: φ5 ※11
φ6 ※12

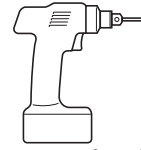

Drill ※9 ※11 ※12



Adhesive for synthetic rubber and wood ※10

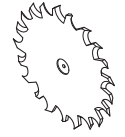

Saw for metal ※11

※9: For installation of flash bolt. As for drill bit φ12, choose suitable one according to the material of the floor.

※10: For installation of gasket (acrylic modification silicon resin, elastic adhesive or the like)

※11: For installation of door bottom tightener.

※12: For hole processing of tracks.

INSTALLATION PROCEDURES

This describes the installation of right stacking. In case of left stacking, positions and direction of the parts are mirror image.

1 Cutting, Hole Processing for Long Parts

[1] Upper track

(Refer to the shop drawing about the cutting length.)

⚠ Caution

❗ Remove any dirt or aluminum chips from the track.

Upper track next to stacking track

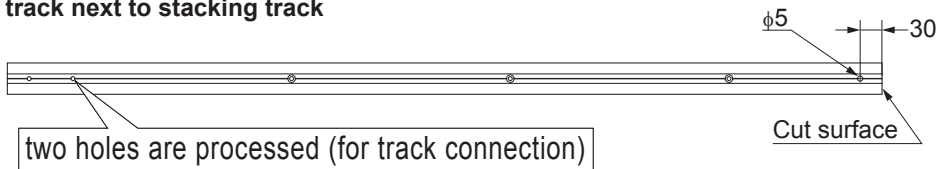

Additional track when using two upper tracks

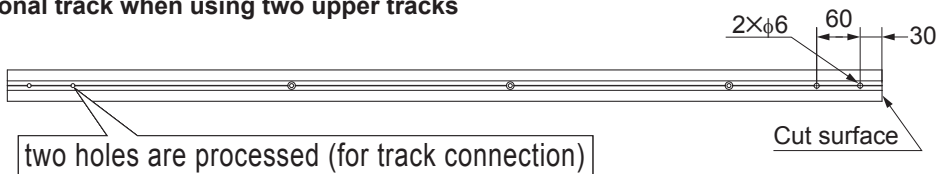

[2] Gasket, Counter part for gasket

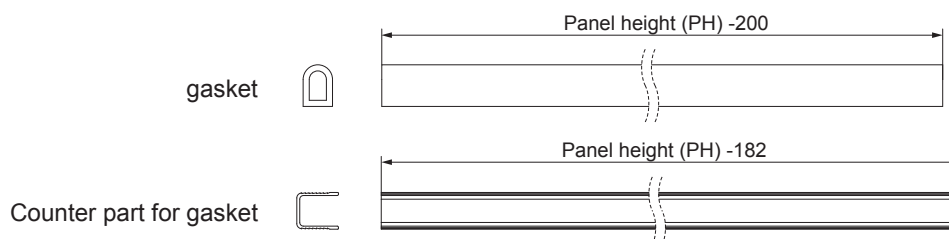

[3] Door bottom tightner

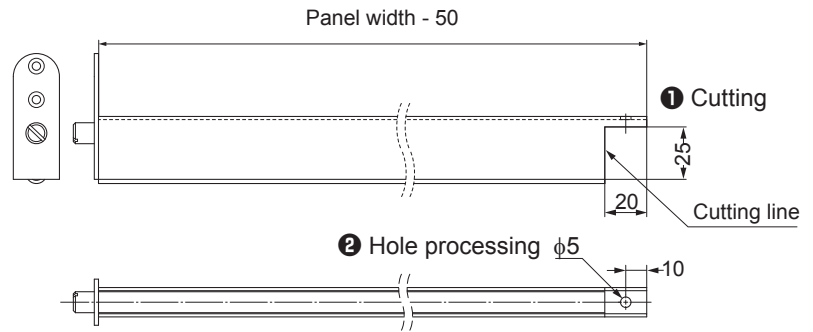

[4] Hanging bracket (when using together with the optional gap cover)

<For panel width : 500 - 519,
700 - 719>

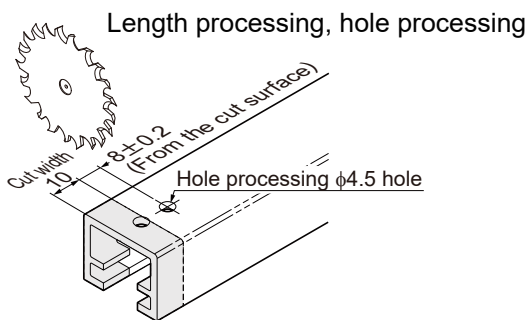

<Panel and door width ≥ 700 >

Hole processing for Catch B installation
(1 hole per piece)

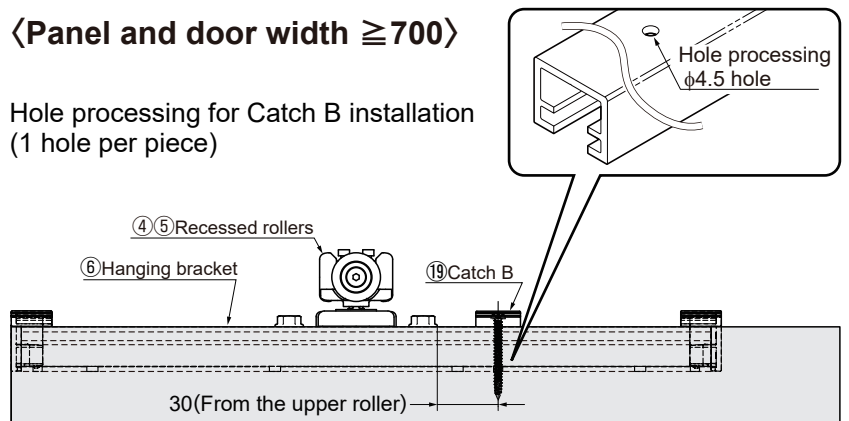

[2] Parts Assembly on Panels

[1] Hanging bracket

Panels to be assembled: Stackable panel 1 - 3 (SP1 - 3)

! Caution

Install bracket leaving 5 mm space from panel end.

Do not fix $\phi 4.5$ hole at the end.

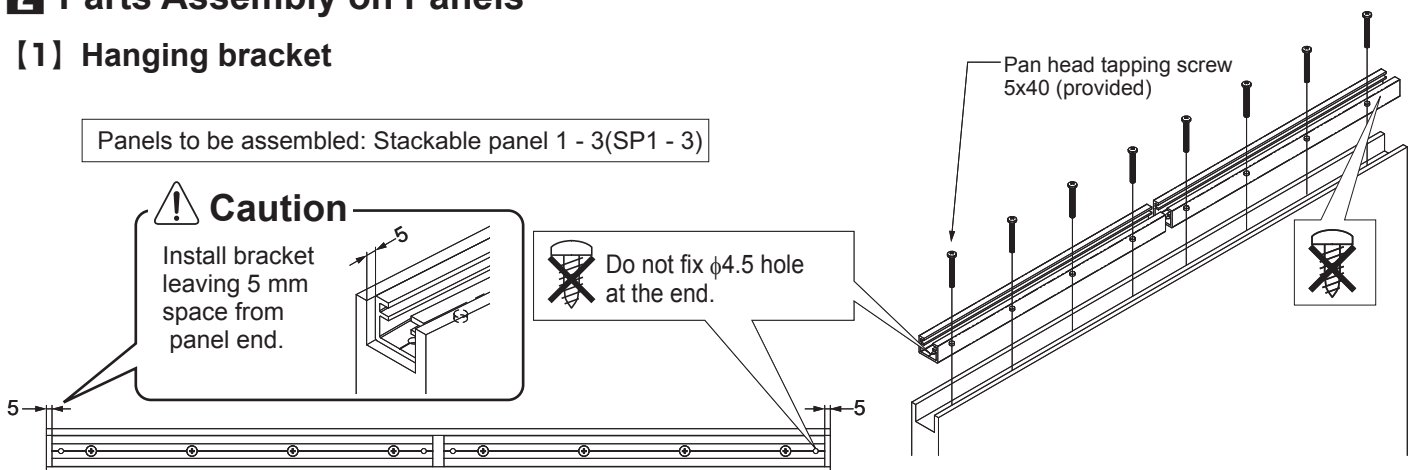

[2] Flash bolt

Panels to be assembled
· Stackable panel 1 - 3
(SP1 - 3)

⑧ Flash bolt

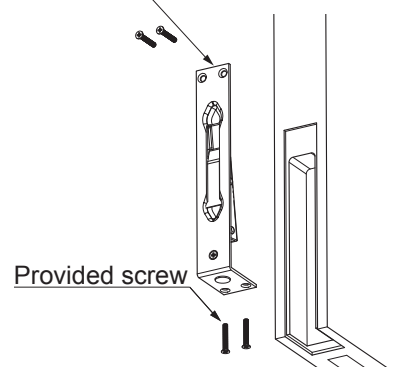

[3] Gasket, Counter part for gasket

Panels to be assembled
See page 3 "Parts for each panel (Optional Parts)".

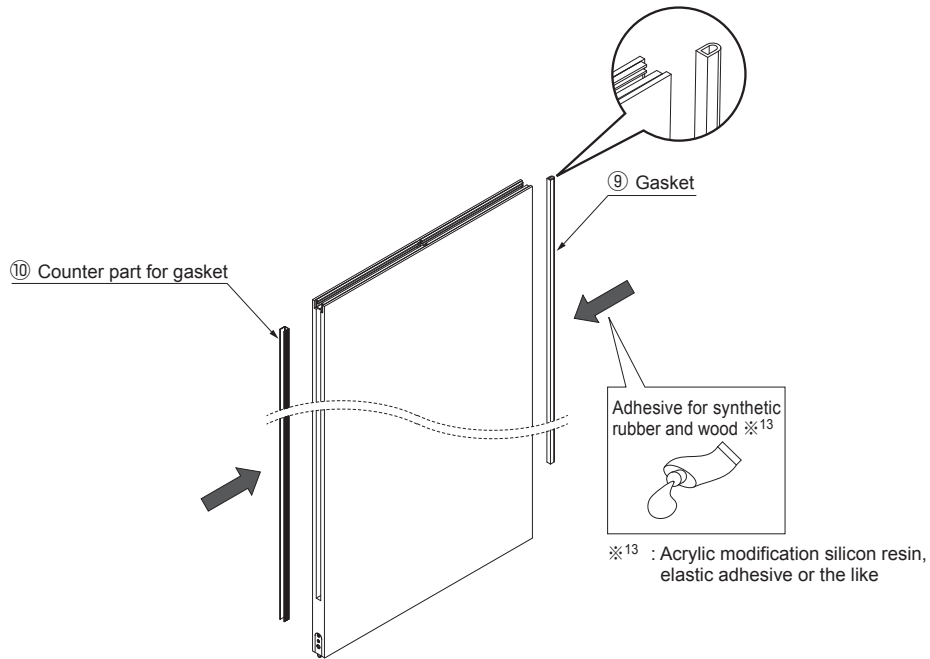

[4] Door bottom tightner

Panels to be assembled
• Stackable panel 1 - 3
(SP1 - 3)

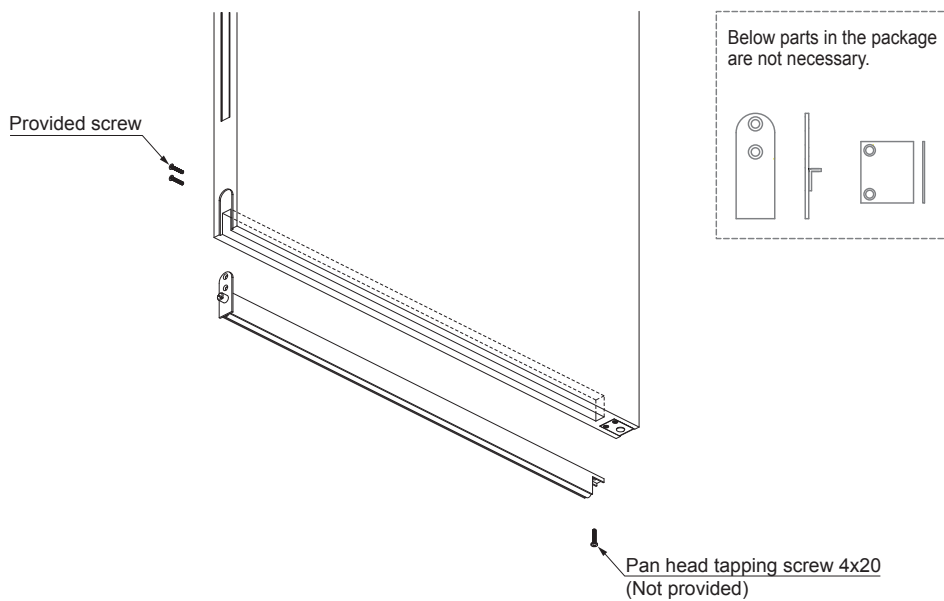

3 Mounting Stacking Track

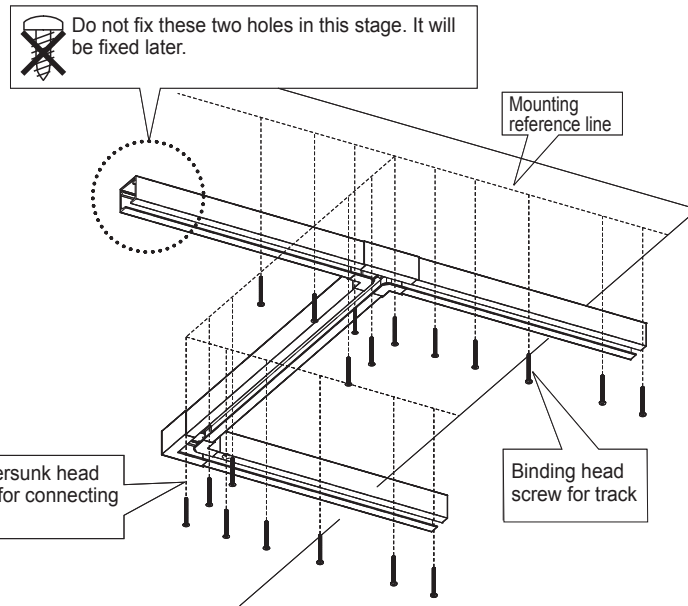
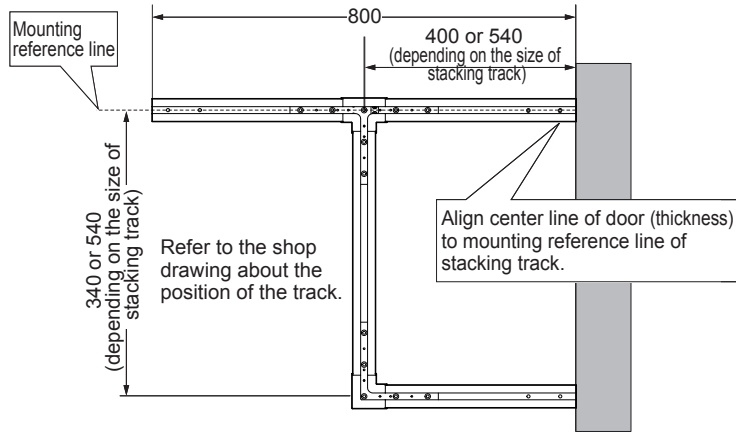

4 Installing Recessed Roller

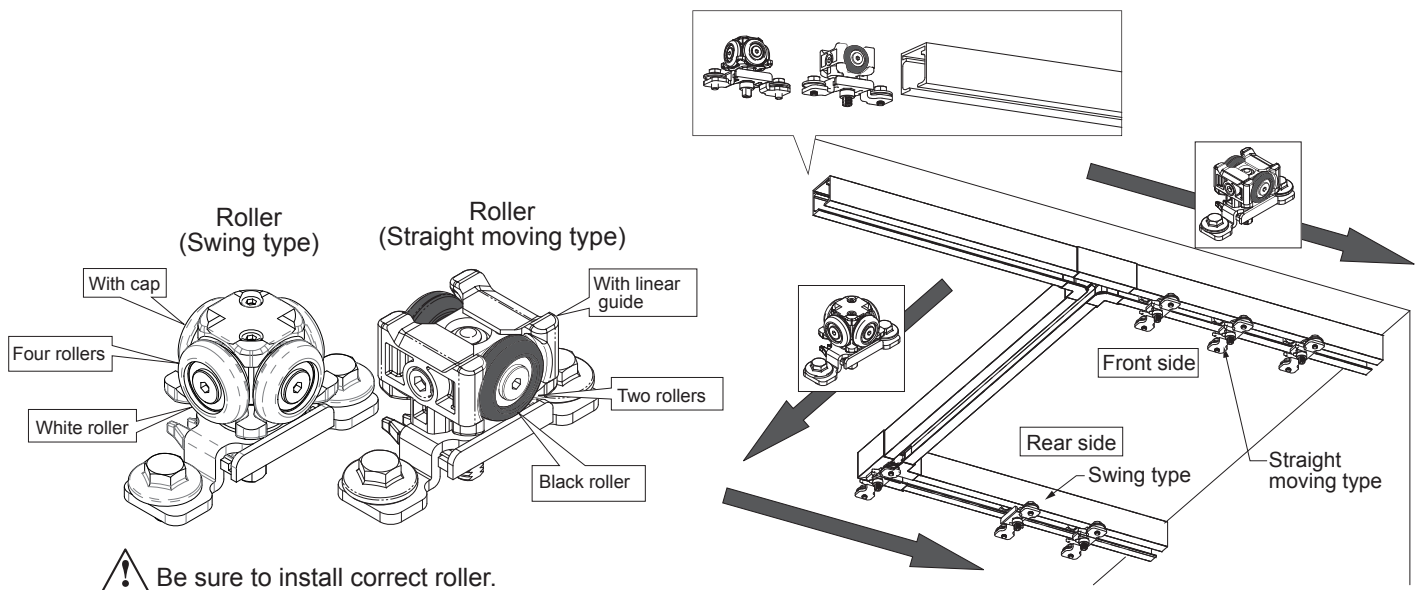

5 Mounting Upper Track

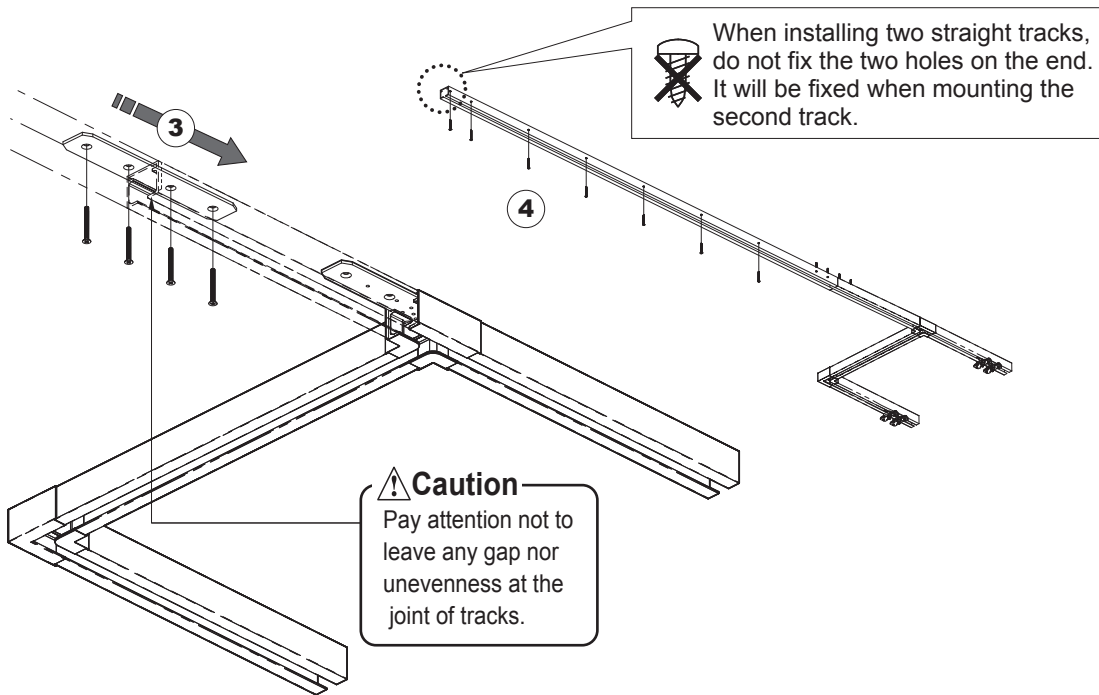
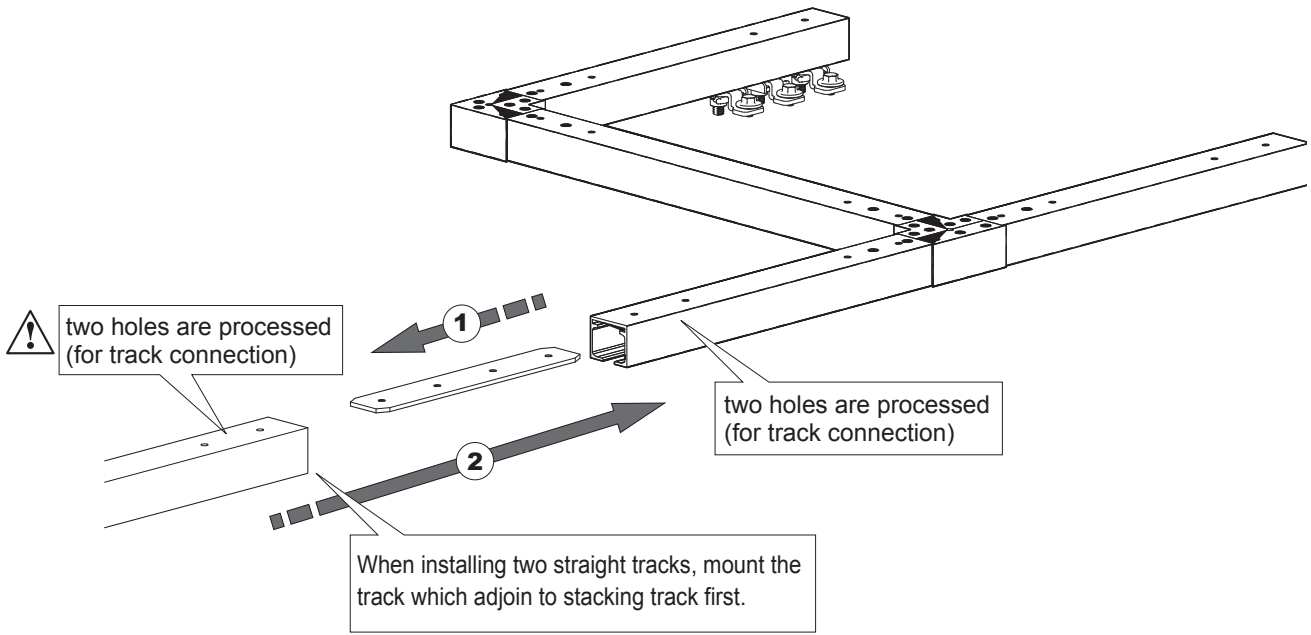

How to joint two upper tracks

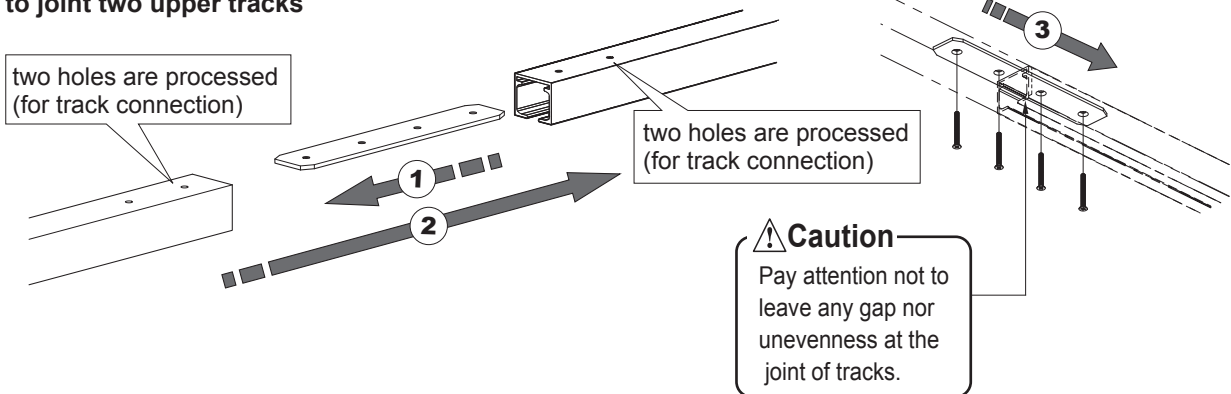

6 Assembling Recessed Rollers, Hanging Panels

[1] Workflow

- ① When installing ⑰ gap cover (option): install catches A and B in the center.
 - ※ Attach Catch B to the opening door at equal intervals.
 - ※ Refer to P.16 for placement and quantity.

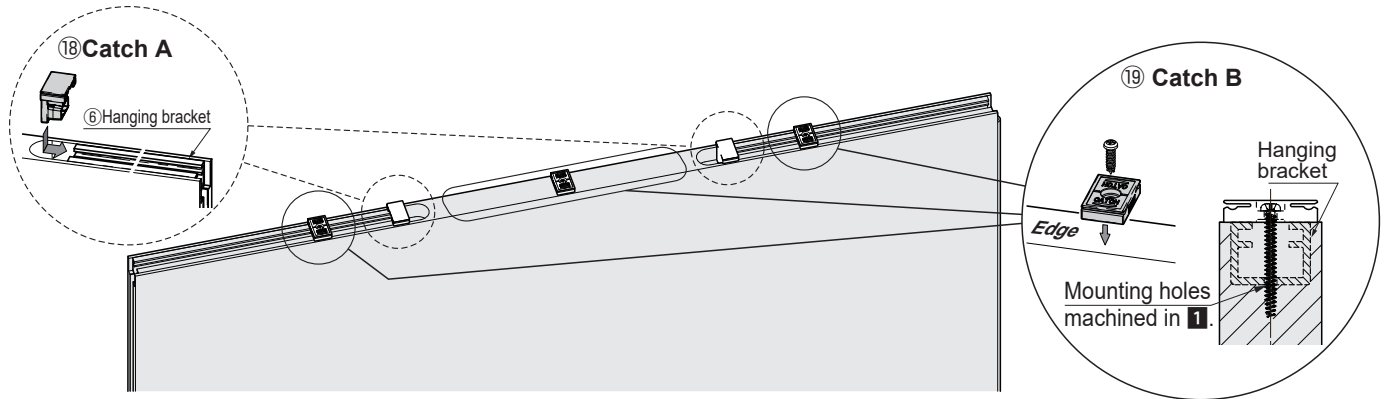

② Hanging Panels

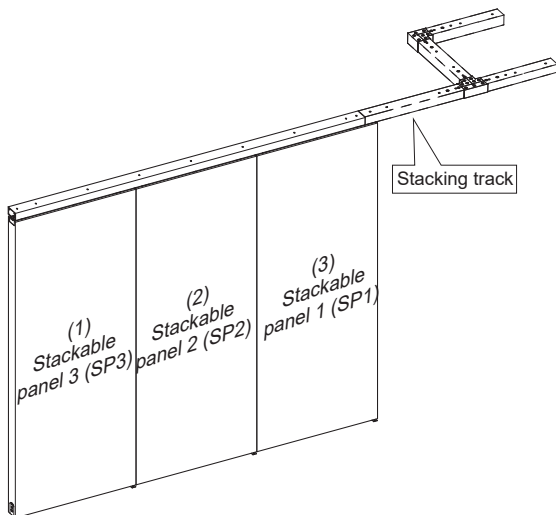

Order of Hanging

- (1) Stackable panel 3 (SP3)
- ↓
- (2) Stackable panel 2 (SP2)
- ↓
- (3) Stackable panel 1 (SP1)

③ Preparation of recessed rollers

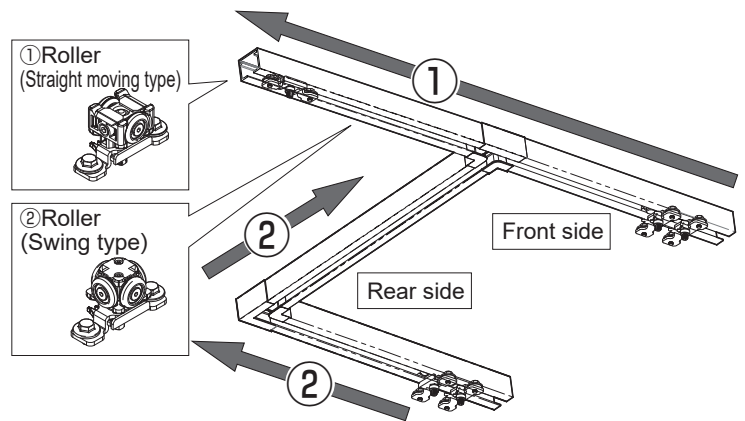

- ① Move straight moving type roller at front side, first.
- ② Move swing type roller at rear side next. (per pair)

- ④ Loosen the tightening bolts on the rollers.

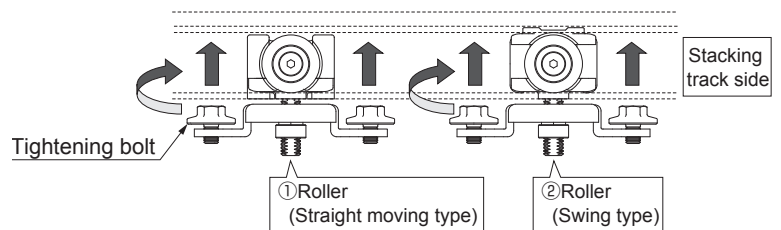

[3] Hanging panels

This describes an example of stackable panel 3 of right stacking.
The panel edge with flash bolt faces stacking track.
In case of left stacking, direction of the parts are mirror image.

⚠ Caution

This work should be carried out by two persons.

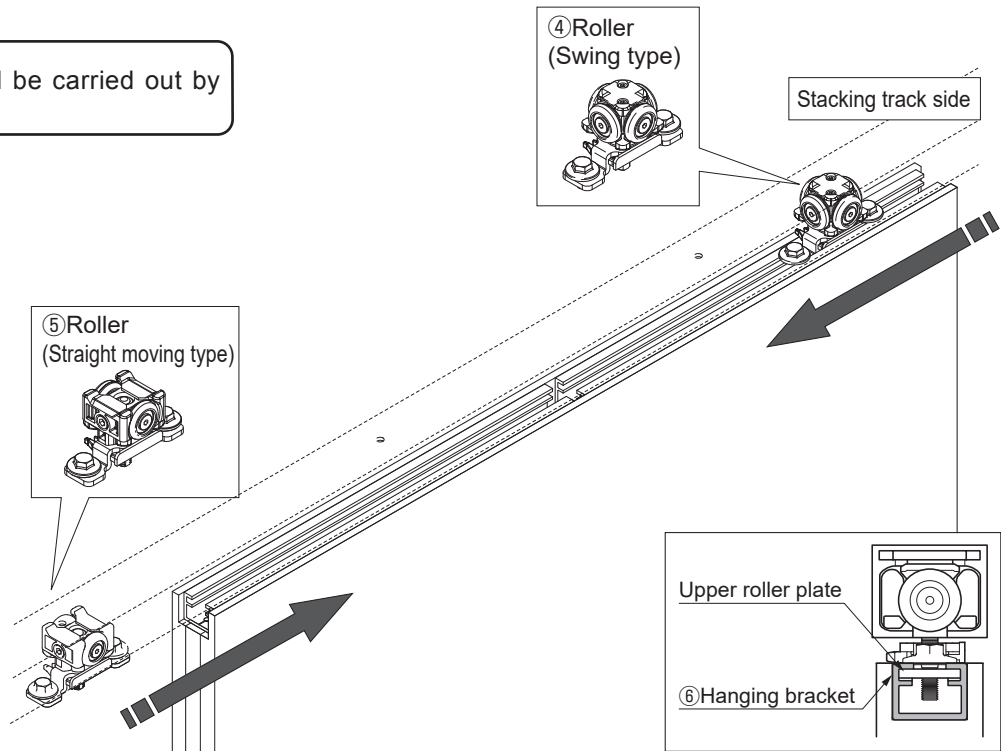

[4] Adjusting positions of recessed rollers, Fixing of rollers

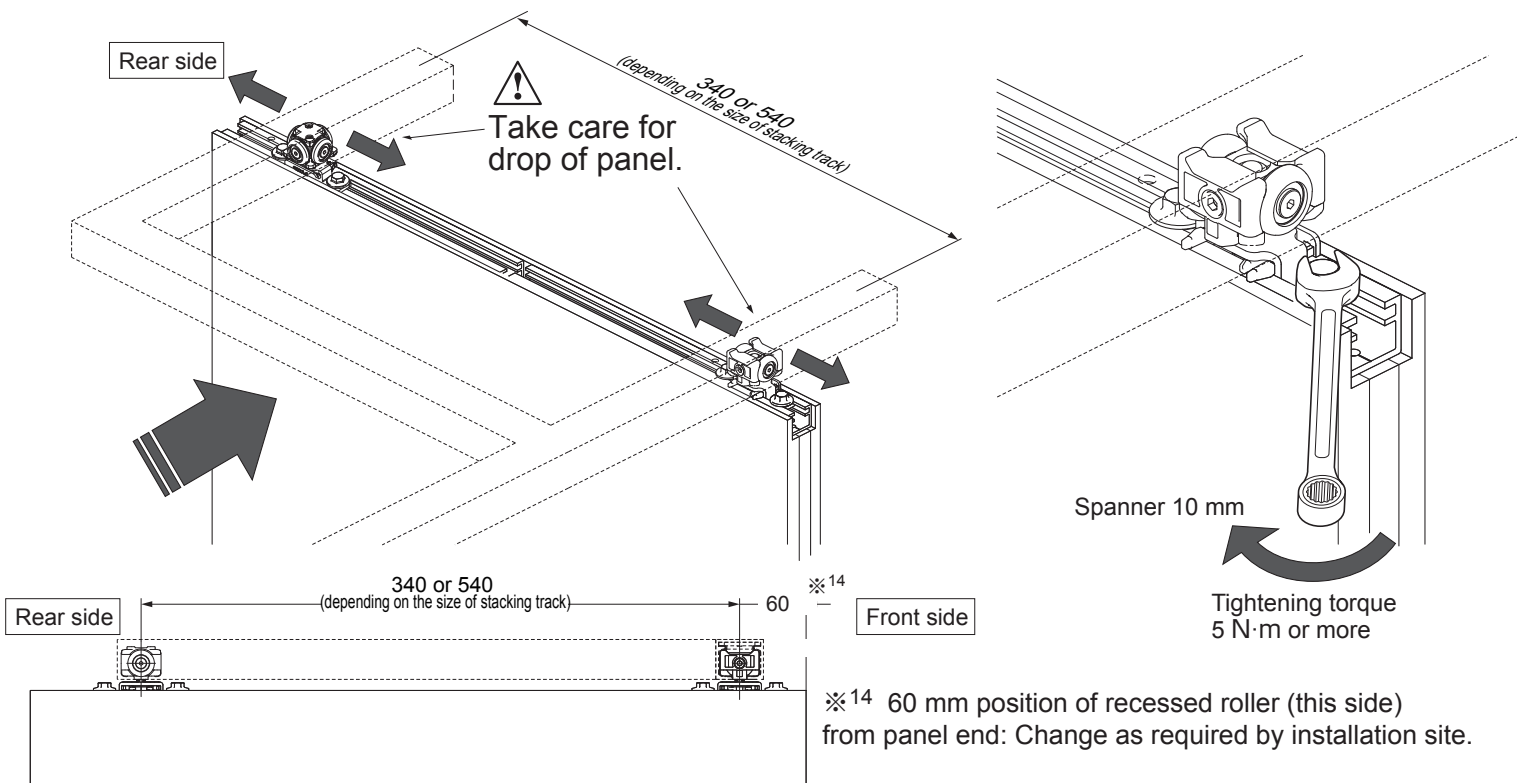

[5] Hanging rest panels, Adjusting roller positions

Repeat above works ([3] and [4]) against Stackable panel 2 (SP2) and Stackable panel 1 (SP1)

7 Check Movement of Stackable Panels

[1] Operation check

Repeat sliding out operation of each panel from stacked position for several times to confirm the position of rollers.

[2] Adjustment

If improper movement is found, readjust the position of rollers.

8 Panel-to-Panel Alignment (Adjusting Vertical Position)

[1] Arrange the panels

Pull out all stacked panels and doors along straight part of the track as shown.

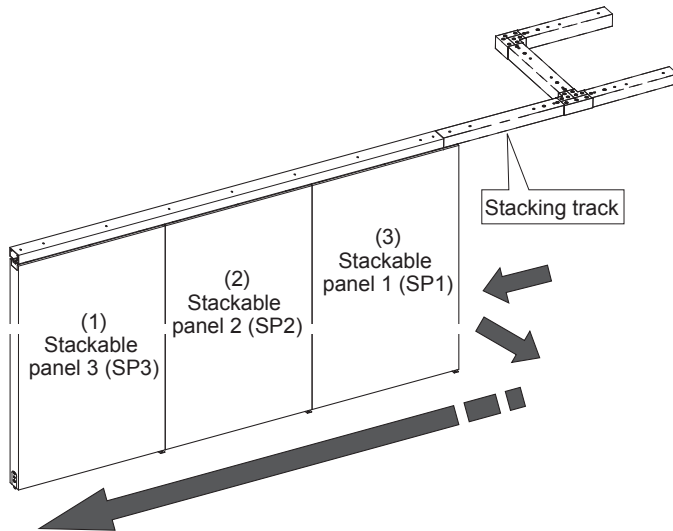

[2] Pull out nut holder.

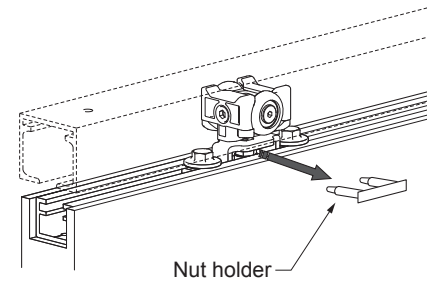

[3] Adjust vertical position.

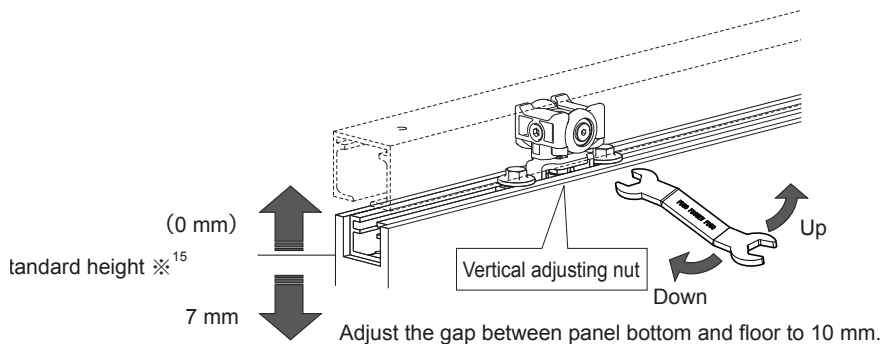

※¹⁵ Default setting;
Gap between track and panel: 10 mm

[4] Re-insert nut holder

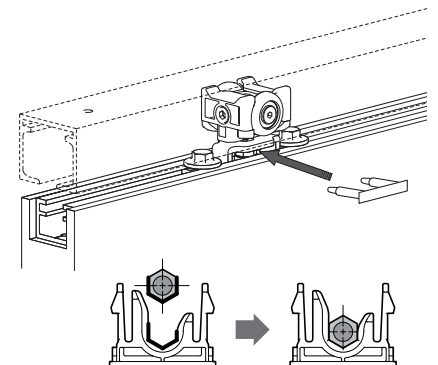

9 Mounting Strike for Flash Bolt

Mount each strike in the order of ① to ③, while positioning one by one.

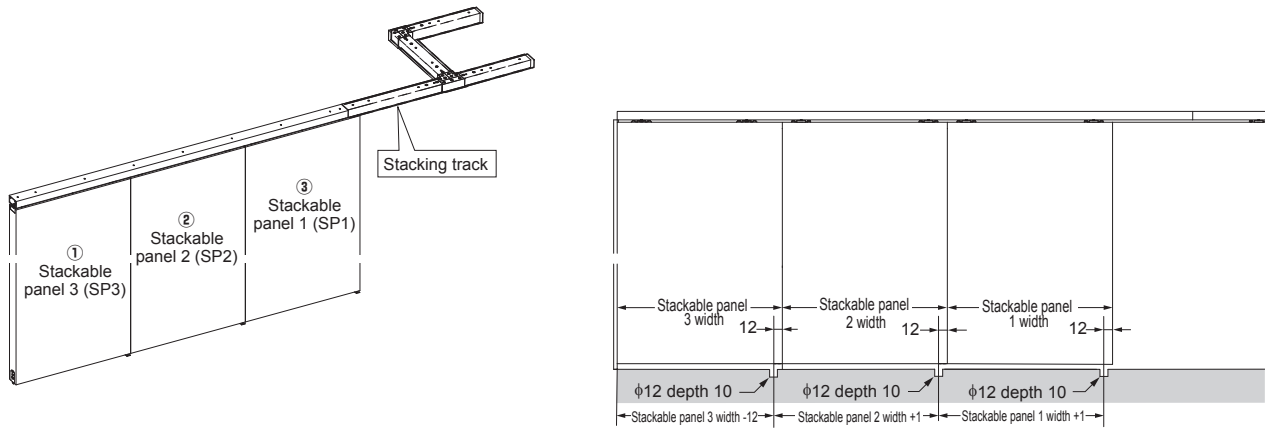

【1】 Position the strike just below the center of upper track.

【2】 Determine the position while closing the panel.

【3】 Drill a hole on the floor. 【4】 Fix the strike with provided screws.

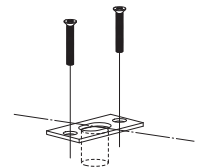
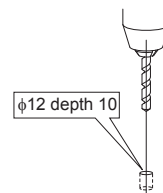
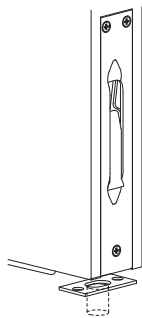
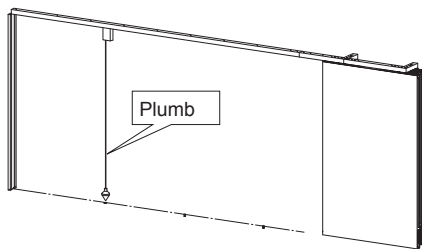

10 Adjusting door bottom tightner



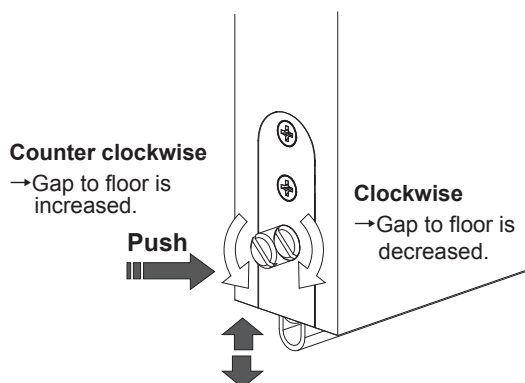

- Adjust the gap by turning the spindle on bottom tightner ①.
- Check the gap also when the panel is locked with flush bolt.

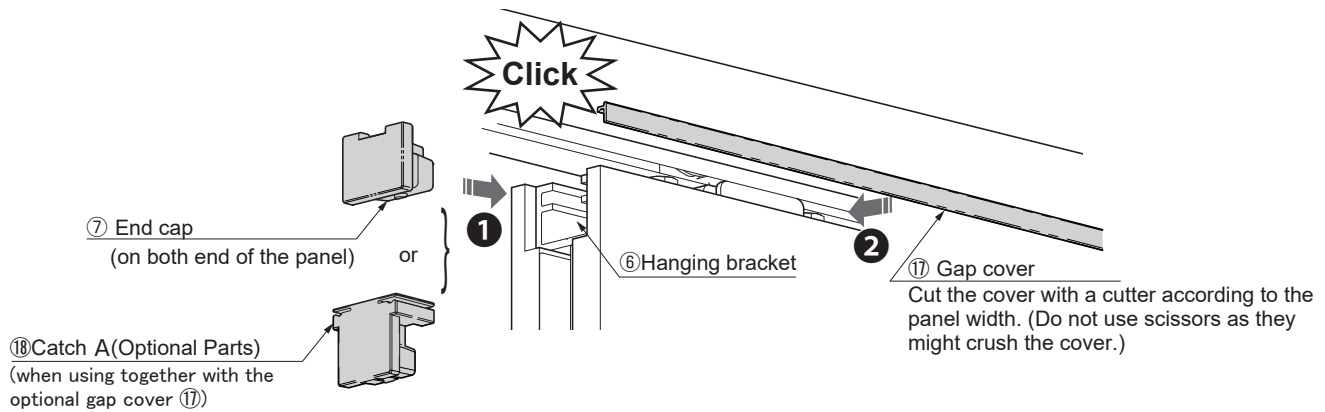

11 Mounting end cap or Catch A

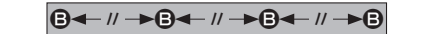

Arrangement of Catch A and Catch B when installing a cover for a gap (per door)

	Panel width	Hanging bracket length	Catch A  A A	Catch B  B		Mounting point (upper door opening) The A is the catch A to be installed at the end.
				Next to upper roller	Center of panel	
Stackable panel	500 ~ 700	240	4 pcs./Set	—	—	—
	700 ~ 900	340		2 pcs. / per panel	—	
Swing door	500 ~ 700	—	—	4 pcs.		
	700 ~ 900	—	—	6 pcs.		

12 TROUBLESHOOTING

TROUBLE	CHECK	SOLUTION
Panel does not go in stacking track.	Check if panel's recessed roller mount pitch deviates from stacking track.	Adjust recessed roller mount pitch. If recessed roller set bolt is loosened, retighten. Refer to 6 - [4] Assembling Recessed Rollers, Hanging Panels.
Panel is caught during operation.	Check if fixing screw on upper track is loosened.	Recessed roller may contact to screw. Loosen the screw.
	Check if upper track is jointed to stacking track correctly.	The connecting part of upper track and stacking track should be connected with provided connecting plate, with no gap and no unevenness. Refer to 5 Mounting Upper Track.
Abnormal sound when sliding panels.	Check if any dirt or aluminum chips remains in upper track.	Clean inside of upper track.
	Check rollers in the track for existence of aluminum chips.	Remove the track and remove rollers, then clean the roller.
	Check if the screw installing track to ceiling for looseness.	Retighten screw to avoid roller contact against screw.
Heavy movement of panel.	Check if panel contacts to the floor.	Confirm track fixing screws are not loosened. Readjust panel height so that clearance between panel bottom and floor becomes 10 mm.
Panels move automatically.	Check if upper track is installed horizontally.	Reinstall upper track horizontally with level gauge.

SUGATSUNE KOGYO CO., LTD.
Tokyo, JAPAN
Phone: +81 3 3866 2260
E-mail: export@sugatsune.co.jp

SUGATSUNE KOGYO (UK) LIMITED
Reading, UK
Phone: +44 1189 272 955
E-mail: sales@sugatsune.co.uk

SUGATSUNE EUROPE GmbH
Düsseldorf, GERMANY
Phone: +49 211 53812 900
E-mail: sales@sugatsune.eu

SUGATSUNE AMERICA, INC.
California, USA
Phone: +1 310 329 6373
E-mail: sales@sugatsune.com

Chicago, USA
Phone: +1 630 317 7072
E-mail: sales@sugatsune.com

SUGATSUNE CANADA, INC.
Montreal, CANADA
Phone: +1 514 312 5267
E-mail: support@sugatsune.ca

SUGATSUNE SHANGHAI CO., LTD.
Shanghai, CHINA
Phone: +86 21 3632 1858
E-mail: lamp@sugatsune.com.cn

Guangzhou, CHINA
Phone: +86 20 6639 3554
E-mail: lamp@sugatsune.com.cn

SUGATSUNE KOREA CO., LTD.
Incheon, KOREA
Phone: +82 32 220 0603
E-mail: sales@sugatsune-korea.co.kr

SUGATSUNE KOGYO INDIA PRIVATE LIMITED
Mumbai, INDIA
Phone: +91 9867299597
E-mail: sales@sugatsune.in
Delhi, INDIA
Phone: +91 9867299597
+91 11 45093636
E-mail: sales@sugatsune.in